

THE ART OF DISGUISE

**R U B I A R. G.
OCT 18TH 2024**

This talk will explore the fascinating world of disguise, a practice that has been employed for centuries by individuals seeking to conceal their true identity or intentions. Hidden in plain sight, these methods can range from simple changes in clothing to elaborate transformations that challenge our perceptions. In this presentation, we will delve into the historical and cultural significance of disguise, examining its role in contexts such as espionage, theater, and social movements. Study of this art reveals intricate ways in which individuals manipulate their appearance to blend in or stand out, depending on their desired outcomes. Unlike mere superficiality, disguise serves as a powerful tool for self-expression, social commentary, and revolution. During our journey, we will uncover hidden meanings and symbols conveyed through disguise, revealing a world where appearances can be deceiving and reality can be obscured. Let us embark on this exploration together, where the lines between truth and fiction blur, and the possibilities for transformation are endless. Such insights can empower us to become more discerning observers of the world around us. In conclusion, the exploration of disguise not only highlights its historical relevance but also invites us to reflect on our own identities. So, join me as we navigate this intriguing terrain. Allowing us to uncover the complex relationship between disguise and identity, this journey promises to be enlightening and thought-provoking. Come ready to engage with the many facets of disguise that shape our understanding of reality. Through this exploration, we will recognize the power of appearances in shaping narratives and identities. Ultimately, this discussion will inspire a deeper appreciation for the artistry involved in disguise. And as we peel back the layers, we'll discover the profound impact it has on society and individual expression. Let us challenge our perceptions and embrace the hidden messages that disguise reveals. Learn how this art form can serve as a reflection of our ever-evolving identities. Your insights and participation will enrich our discussion as we delve into the vibrant world of disguise. At the heart of this presentation lies the idea that understanding disguise can empower us to see beyond the surface. By recognizing the symbols and meanings intertwined with disguise, we can better appreciate its role in shaping human experience. Open your minds to the endless possibilities that this art form offers, and let us explore together. Uncover the layers of meaning that disguise holds, revealing a world that invites curiosity and reflection. This journey promises to illuminate the intricate dance between identity and appearance, leaving you with a renewed perspective. Fascinating patterns emerge when we examine the use of colors and symbols in various forms of disguise. Let's embark on this journey through the art of disguise, where every layer tells a story and every symbol holds significance. As we engage with this topic, we will uncover the truths hidden beneath our own façades. Gather your thoughts and prepare for a dialogue that challenges perceptions and celebrates the power of disguise. So join me as we delve into this compelling exploration, enriching our understanding of ourselves and the world around us.

This talk will explore the fascinating world of disguise, a practice that has been employed for centuries by individuals seeking to conceal their true identity or intentions.

Hidden in plain sight, these methods can range from simple changes in clothing to elaborate transformations that challenge our perceptions.

In this presentation, we will delve into the historical and cultural significance of disguise, examining its role in contexts such as espionage, theater, and social movements.

Study of this art reveals intricate ways in which individuals manipulate their appearance to blend in or stand out, depending on their desired outcomes.

Unlike mere superficiality, disguise serves as a powerful tool for self-expression, social commentary, and revolution.

During our journey, we will uncover hidden meanings and symbols conveyed through disguise, revealing a world where appearances can be deceiving and reality can be obscured.

Let us embark on this exploration together, where the lines between truth and fiction blur, and the possibilities for transformation are endless.

S...

IS ACTUALLY ABOUT FLAGS

FLAGS

FLAGS

FLAGS

FLAGS

FLAGS

FLAGS

A S H E A .
OCT 18TH 2024

Flags: An Unofficial Comprehensive Overview

“A thoughtful mind, when it sees a nation’s flag, sees not the flag, but the nation itself.”
- Henry Ward Beecher

Who am I?

- Ashe Adam (they/them)
- Not actually UBC staff or faculty
- But dating someone wonderful who is
- Artist, VFS instructor, Fighting Game Enthusiast
- But most importantly...
- Infodumper about flags!
- Buckle in



“Portrait”

Image courtesy of Getse Perez

Estimated 2024

Ink on paper (Digital)

My Credentials

- This is where it all started
- Thanks Mom <3
- This book is huge!
- It's also from 1994!
- Extinct countries like Yugoslavia, Zaire or Dutch Antilles exist
- Since then I've always been a hobby Vexillologist

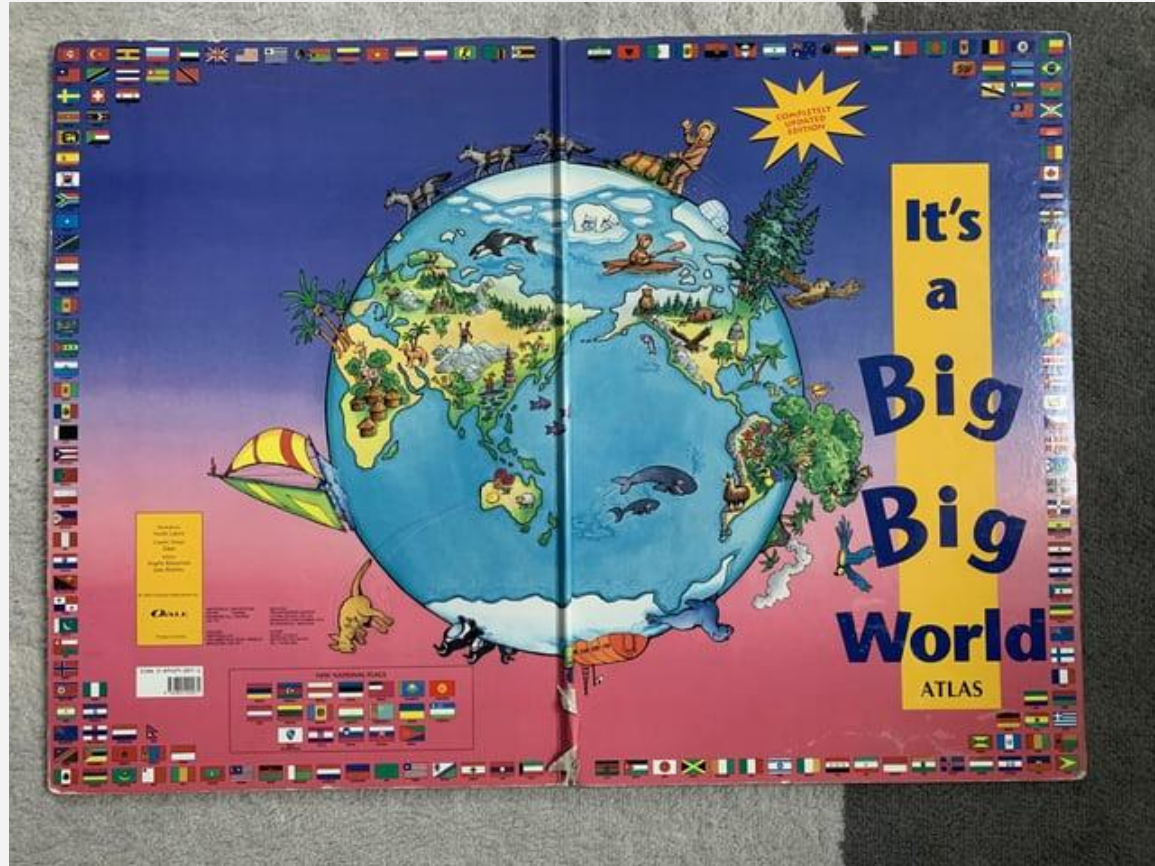

Drinking Game!!!

- I will ask questions or to identify certain flags
- You will raise your hands
- If I choose you and you're right you get to choose someone to drink
- If you're wrong you have to drink
- You can choose multiple people but if you're wrong you have to take equivalent drinks
- If you blurt out an answer without being selected you have to finish your drink
- If no one raises their hand or no one can get it then everyone drinks



**The answer will be provided in
small text like this in bold!
(please drink responsibly)**

What is a Flag?

- Flags: colorful fabric symbols, most often rectangular.
- Used for signaling, decoration, or symbolism.
- Often hoisted on poles, but not always.
- "Vexilloids" = flag-like objects.
- Represents countries, ideas, or anything else!

Q: What is the oldest national flag that is still used today?(Pictured on the right)

Bonus Q: How old is it?



A: Denmark!

- Recognised as national flag in 8 May 1625; 399 years ago

A brief(ish) history of flags

- Flags have come a long way since being bloody rags on staffs
- Prehistoric times flags: usually bloody rags on staffs
- Ancient China implemented silk which spread to the rest of the world
- Age of chivalry and Japanese “Hata-Jirushi”
- Flags = “Our Team” (more or less)
- “Modern Era”: ~16th Century or so

Q: This Asian banner is one of the oldest known examples of early vexillology with their current day equivalent pictured below

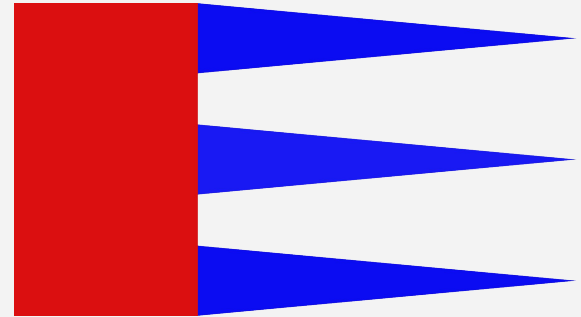

A: Mongolia!

Let's talk Principles!

- Flags are an art form
- Although still subjective, there are principles to good flag design
- Five Principles defined by Ted Kaye
- All rules have exceptions however
- “Depart from these five principles only with caution and purpose”

Q: Some examples of great modern flag design from each continent!

**A:(top left to bottom right)
Canada, Argentina, United Kingdom, Kenya, South Korea, Vanuatu**

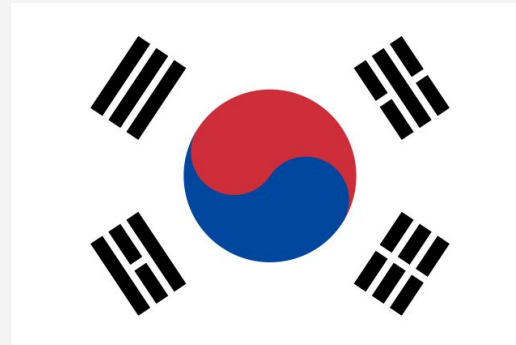
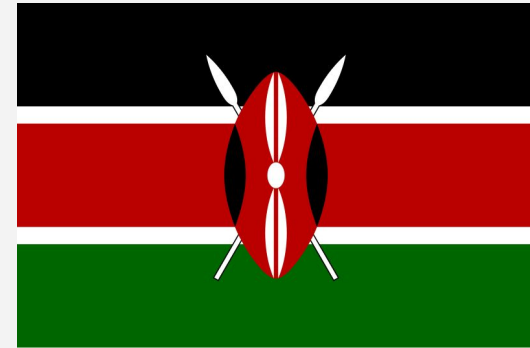
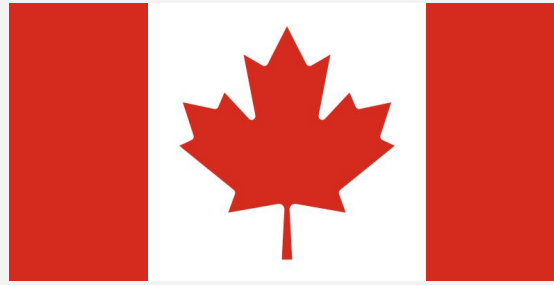

Principle 1 - KEEP IT SIMPLE

- Flags flap, flags drape, should still be recognizable
- Should be identified reversed too!
- A child should be able to draw it from memory
- *Most bad flags are redeemable

Q: These two asian flags represent their countries, one simply and effectively with bold colors and symbols

The latter pays homage to historic rugmakers which unfortunately clutters the design

Here's a hint for the latter: 🐔+👤+istan



A: China and Turkmenistan!

Principle 2 - USE MEANINGFUL SYMBOLISM

— — —

- Colors, Images, Patterns and Layout should relate to what the flag symbolizes
- Usually a single unique primary symbol is best
- Symbols should consider their history and be evocative
- This is not a renaissance painting, go for simple silhouettes
- A silhouette of a country is an exception, it's a flag, not a map. Don't do this.

Q: These two EU member states flags have both make use of symbolism:

The upper flag uses blue and yellow to symbolize its skies and wheat that its famous for

The lower flags country silhouette symbolizes... its country



A: Ukraine and Cyprus!

Principle 3 - TWO TO THREE BASIC COLORS

- Stick to standard colors
- Blues, Reds, Yellows, Greens, Whites, Blacks, etc
- No magentas please
- Contrast is a necessity
- NO GRADIENTS FOR THE LOVE OF GOD
- 2-3 Colors Max (Mostly)

Q: These Two African flags south of the equator both violate the “2-3 colors max rule” and still look great. They both also start with an S



A: Seychelles and South Africa!

Principle 4 - NO LETTERING OR SEALS

- Languages aren't universally understood.
- Writing on flags can become illegible.
- Iconography needing annotation is ineffective.
- A flag is not a banner.
- Words on flags are problematic.

Q: These two countries south of Mexico both start with a B and violate the “no words rule”

While the upper one gets away with it for other good flag principles the lower isn't so lucky



A: Brazil and Belize!

Principle 5 - BE DISTINCTIVE OR RELATED

— — —

- Sometimes a good design is already taken
- Avoid duplicating other flags
- Show connections when possible (like pan african colors)
- Remain Distinct

Q: The bottom left flag closely resembles the one above, symbolizing its founding by former Caribbean slaves while still being distinct

The tricolors below are unrelated, differentiated only by slightly different colors and the same aspect ratio. Good luck!

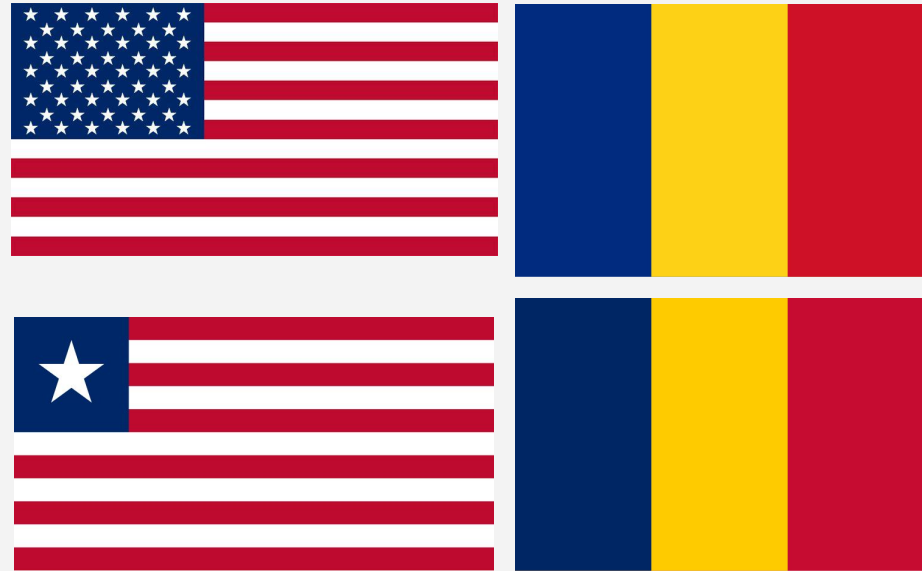

A: (left) United States and Liberia

(right) Romania and Chad

BONUS ROUND!

— — —

Despite sharing similar colors and designs these three flags have no correlation with one another!

Isn't that fun?

Do your best to guess which is which!
(btw they are not in the order of the hints :^)

- One is an *indo* pacific country
- One is a central European country, one of the first to be invaded by Nazi Germany
- And one is a tiny european microstate country southeast of france famous for its casinos

A: (Top to bottom) Poland, Monaco, Indonesia

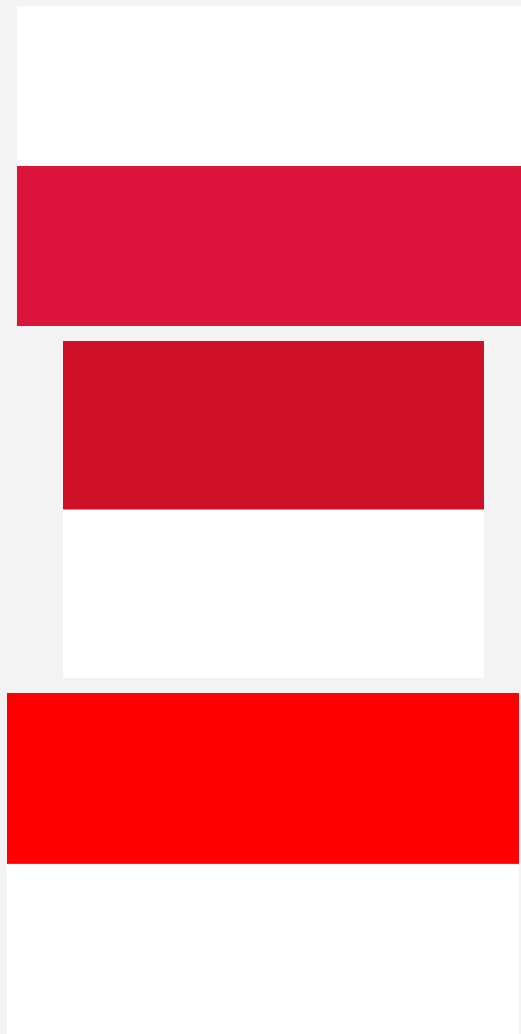

Let's talk colors - Common Color Motifs/Meanings

- The three most common colors are Red, White and Blue. Followed by Green, Yellow and Black
- Red: Bloodshed, Sacrifice, Martyrs, Courage
- White: Peace, Purity, Harmony, Surrender
- Blue: Water, Oceans, Liberation or Good Fortune
- Green: Agriculture, fertility, youth or hope
- Yellow: Sun, Wealth (Gold) or Happiness
- Black: Ethnicity, Death or Defeat of enemies

Q: This Caribbean Island flag is the only country flag to not have the colors Red, White or Blue. What is it?

Bonus Q: This rare color only shows up on two country flags: Nicaragua and this one. What is it?



A: Jamaica!

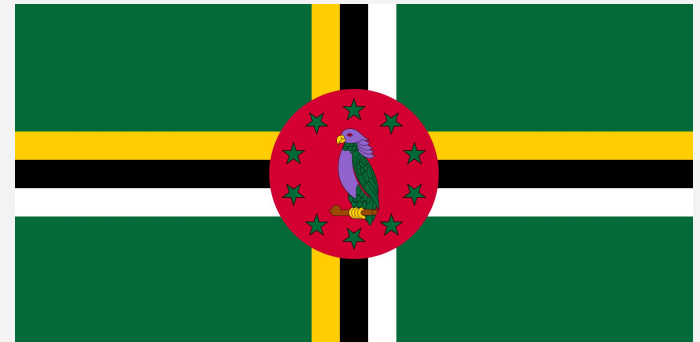

A: Purple! This is Dominica

Tricolors: Another Brief History

- A color scheme and pattern to stay
- One of the first Tricolors was this Flag! **Q: What is it?**
- Then copied by the French and The Russians
- Who in turn were copied by other Europeans
- This is why there are so many tricolors in Europe



A: The Netherlands!

Pan African Colors

- So a lot of Africa was dealing with colonization
- One of the first countries to break free from colonization was this one

Q: Which Country is it?

- Many african countries followed suit
- Pan African Colors: Green, Yellow and Red
- What's the problem with this you ask?



A: Ethiopia!

Side Rant - Pan African Colors

- — —
- I can barely tell these apart
 - Remember principle 5? Be distinct?
 - All of these flags merge together in my mind
 - Also frequently makes use of 5 Point Star
 - Lessens impact

Q: Can you name any of these?



A: (Top left to bottom right) Benin, Burkina Faso, Cameroon, Republic of the Congo, Ghana, Guinea, Guinea-Bissau, Mali, Senegal, Sao Tome and the Principe and Togo

And while I'm at it...

US STATE FLAGS SUCK, AMERICANS
STEP TF UP

LOOK AT THESE EYESORES THEY ALL
LOOK THE SAME

THEY'RE ALL STATE SEALS ON A BLUE
BACKGROUND

SOME EVEN HAVE THEIR NAMES PRINTED
ON THEM

California is also bad but it's at
least iconic so it gets a pass

**Q: Can you name these
vexillological disasters?**

**A: Michigan, Indiana, Oklahoma,
Connecticut, South Dakota and
Delaware**

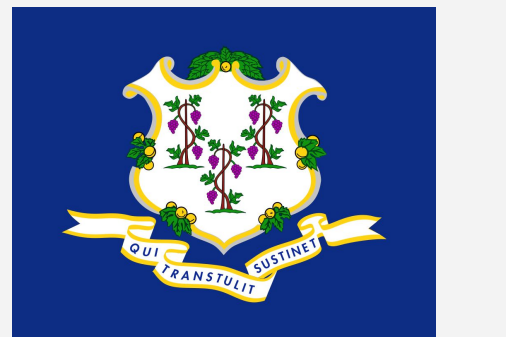
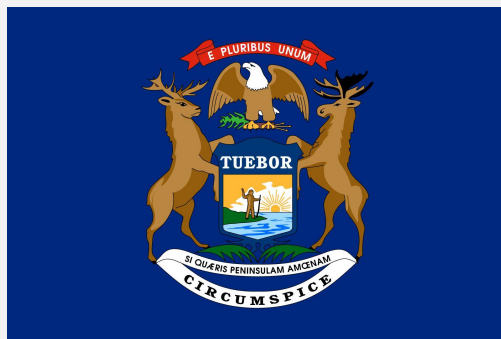

Oh you thought I was done ranting

- It's not ugly???
- Makes absolutely zero sense
- Why the Union Jack???
- This flag is stupid
- I hate it here
- Get it together America

Q: Everyone Drinks I don't care

(It's Hawaii)

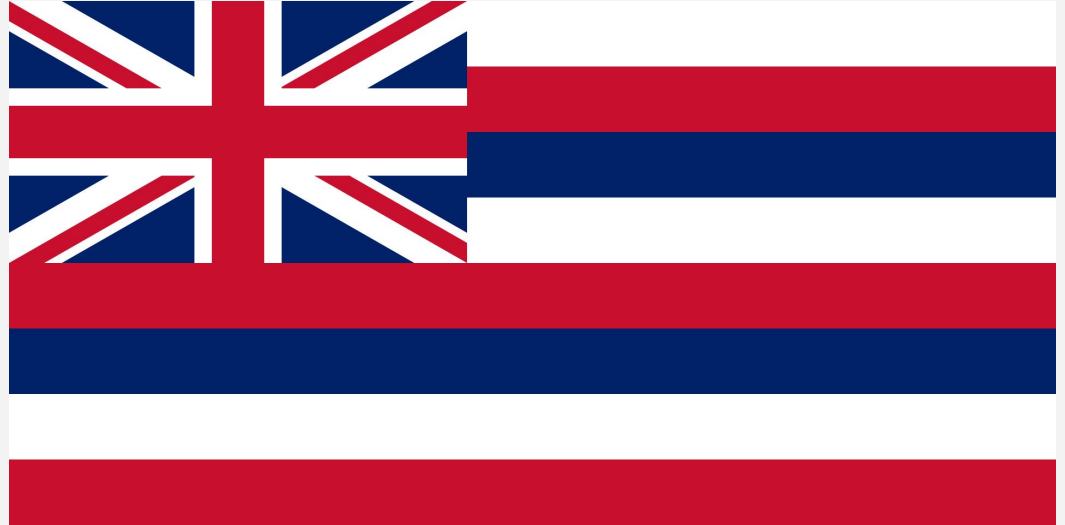

Though there are some good ones...

- Alaska and Texas are simple yet effective
- Maryland may be ugly but its iconic (we love a hot mess)
- New Mexico is phenomenal

Q: Can you name which thin south american country flag looks remarkably similar to Texas?

A: Chile!



And there is hope

- By phasing out their hideous state seals on blue backgrounds
- Or by getting rid of the confederate flag in 2021 (I'm looking at you Mississippi)
- Things seem to be looking up

Q: Can you name these two rag to riches states?

How about now?



A: Minnesota & Utah

Amazing Video about US state flags by CGP Grey



<https://www.youtube.com/watch?v=l4w6808wJcU&pp=ygU0Y2dwIGdyZXkgZmxhZ3M%3D>

Canadian Province Flags are so much better 🍌🗑️

- Look at these bangers
- This is totally not selection bias
- Im totally not showing only the best ones
- I promise

Q: Can you name these beauts?

A: Nunavut and Quebec

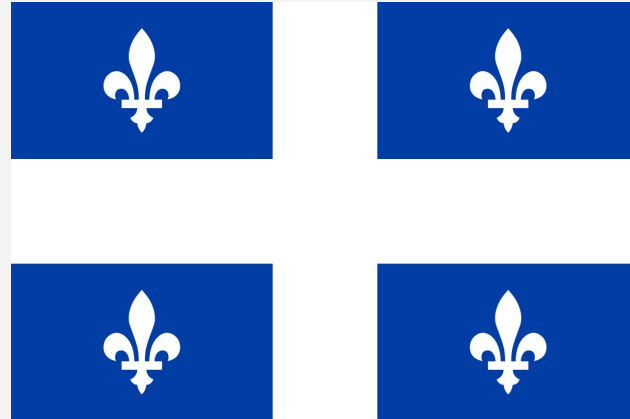

I don't know where to fit this in but I wanna quickly talk about Queer Flags

- Original rainbow flag - 10/10
- Progressive Pride - 8/10
- "New" Pride Flag - 2/10
- Current Pride Flag - 6/10



Q: What does the purple circle with yellow represent?

A: The Intersex Community!



The individual pride flags are great!

— — —

- Bisexual pride flag is so powerful it coined the term “bisexual lighting”
(yes that’s from wikipedia)
- Trans Flag is also iconic
- If not problematic (depends who you ask)
- This is where pride flags shine



An important video



<https://youtu.be/r3fD5FPQBtl>

Flag Anatomy - Bisections

Bisections are what it says on the tin:
dividing the flag into two distinct sections.

- Don't ask me what a sinister is I don't know
- Apparently it's latin for left side?

Q: Can you name any of the bisections we've seen so far in this presentation?



Vertical Bisection



Horizontal Bisection

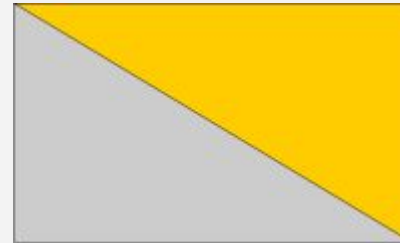

Diagonal Bisection
(per bend)

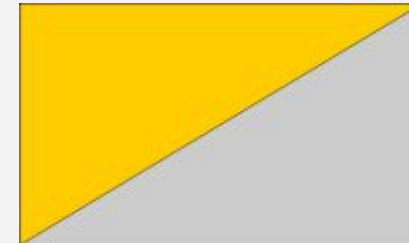

Diagonal bisection
(per bend sinister)

Three's a crowd - Tricolors, Pales and Fess' Oh My!

— — —

- Three Vertical stripes of different colors is called a Tricolor, aptly named
- These are very common in Europe but also the rest of the world
- A tricolor on it's side is still a tricolor but now it's horizontal!
- A tricolor with two colors instead is called a Pale
- A Pale on it's side is a Fess

Q: One of these flags is not like the others, one of these flags just doesn't belong!

A: In order the flags are France, The Netherlands, Peru and Austria.

The odd one out is Peru as the others are all European!

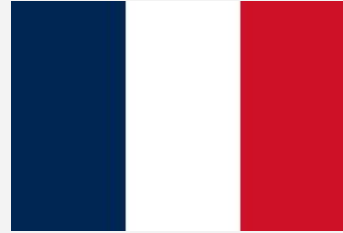

Tricolor



Horizontal Tricolor

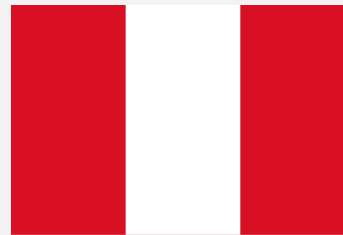

Pale



Fess

Flag Anatomy Cont'd - That Jesus Guy Sure was Popular

- Crosses are a very common motif
- Greek Crosses are pretty uncommon
- Latin Crosses show up more frequently in the Symmetric and Nordic Cross
- Diagonal crosses are also called Saltires or St. Andrew's Cross

Q: Can you name these Cross bearing flags?

A: Switzerland, England, Sweden and Scotland

Bonus Q: How many countries have the Nordic Cross?

A: Five! Iceland, Denmark, Sweden, Norway and Finland



Greek Cross



Symmetric Cross



Nordic Cross



Diagonal Cross

The Glorious (or Hideous) Canton

- A canton is a rectangle or square in the top left of a flag, usually taking up a quarter.
- It can feature simple designs like a star, cross, or even another flag.
- Common in colonizer flags, with the Union Jack often appearing in British colonies.
- Speaking of (former) british colonies!

Q: Can you name these Canton Bearing flags?

One of them probably has people that speak “Cantonese” in it

A: Greece, Australia and Taiwan



Greek Cross Canton

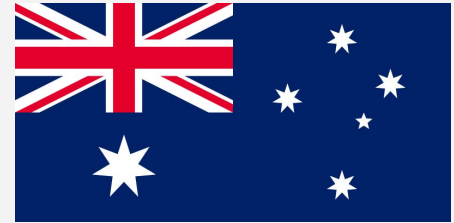

Union Jack Canton

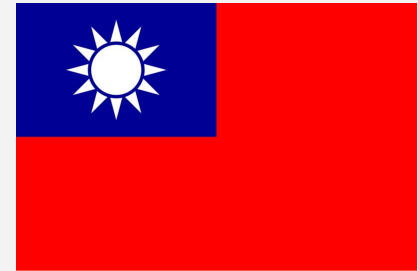

Cantons can be anything!

Flag Anatomy Cont'd

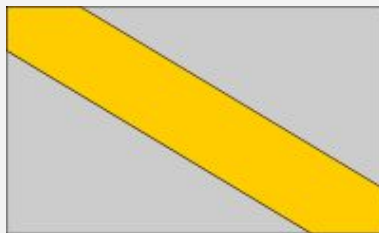

Bend (or Bend Sinister if Reversed)

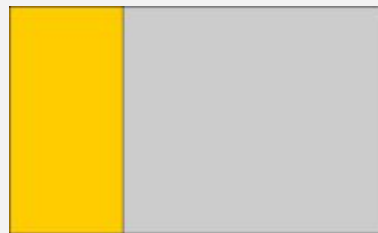

Side (or Side Sinister if Reversed)

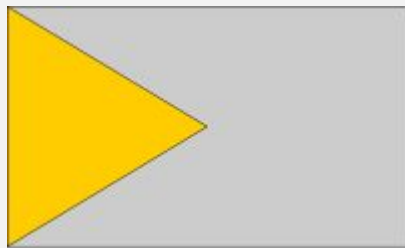

Pile

(called Pile Throughout if touches end of flag)



Bordure



Chief



Base

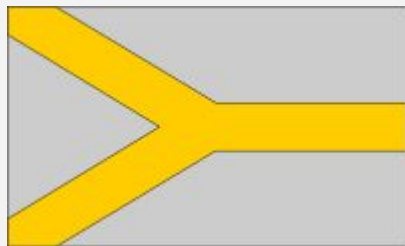

Pall

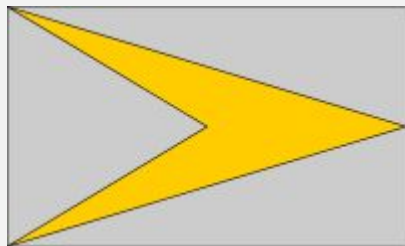

Arrowhead



Quadrisection

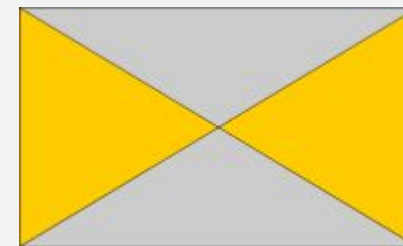

Diagonal Quadrisection

Flag Anatomy - Ratios

- Different flags have different aspect ratios
- A ratio is just its width divided by its height
- The most common is 2:3 Followed by 1:2 and then 3:5
- The remaining 35 sovereign states use a variety of oddball ratios which we'll get into in a sec

Q: Can you name these flags and their aspect ratio? (Hint: they're the three most common ones)

**A: Germany with 3:5
North Korea with 1:2
India with 2:3**



Getting Weird With It

Here are some very unique ratios!

- 11:28
- $1:\varphi$
- Uhhhhhhhhhhhhhhhhhhhh.....

Q: Can you name any of these weirdos?
(one of them was briefly shown in my pan african color rant)

A: Qatar, Togo and Nepal!



it gets worse

You want the ratio for Nepal?
Oh, I'll give it to you.

$$1 : \frac{6136891429688 - 306253616715\sqrt{2} - \sqrt{118 - 48\sqrt{2}} (934861968 + 20332617192\sqrt{2})}{4506606337686} \approx 1:1.21901033\dots$$

(OEIS: A230582).^[18]

This ratio is the least root of the [quartic polynomial](#)^[19]

$$243356742235044r^4 - 1325568548812608r^3 + 2700899847521244r^2 - 2439951444086880r + 824634725389225,$$

I know this makes sense to you smart
compsci students but i'm just a dumb
dumb artist and my brain hurts
(everyone drinks)

so much worse (yes these are real design guidelines)
everyone drinks again

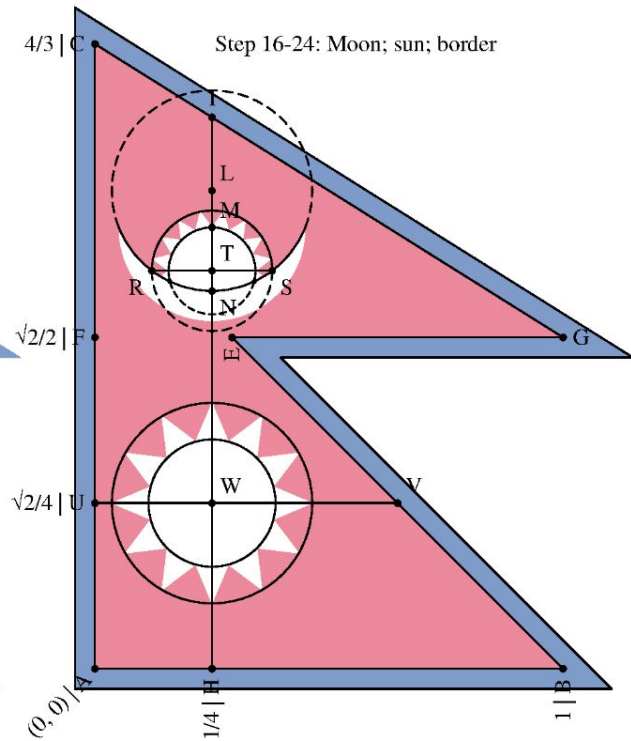
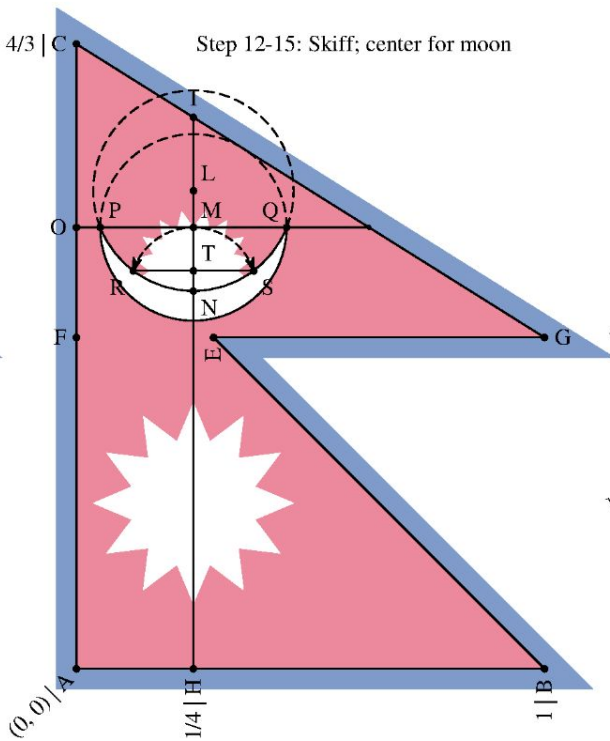
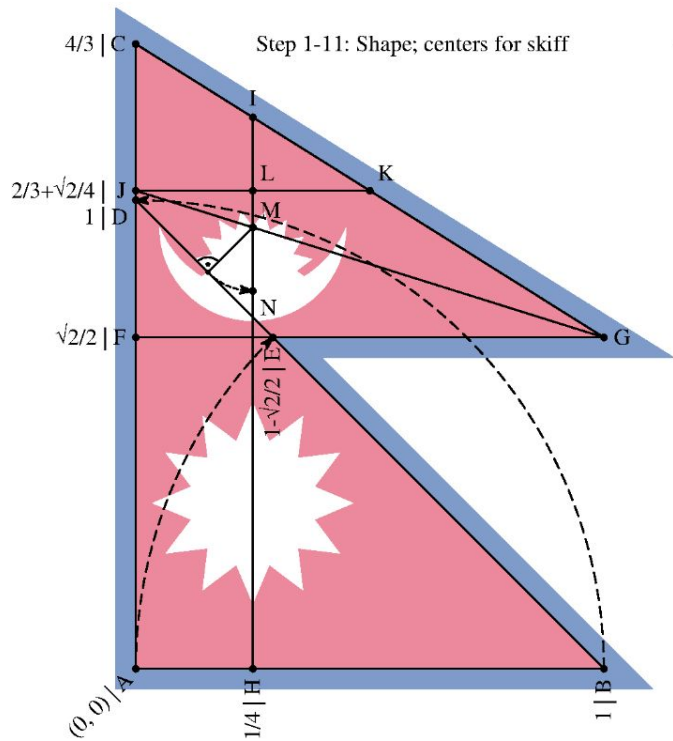

Let's move on to something else!

Extinct Flags!

- Unfortunately some flags are no longer with us 😞
- Flags change when nations crumble or new political factions take over.
- Sometimes you're Gaddafi and you really like the color green
- Some of these were great flags
- Most were not
- More often than not it was probably for the best they were phased out

Q: Can you name any of these extinct flags or their current day counterparts?

A: Georgia, Rwanda and Libya

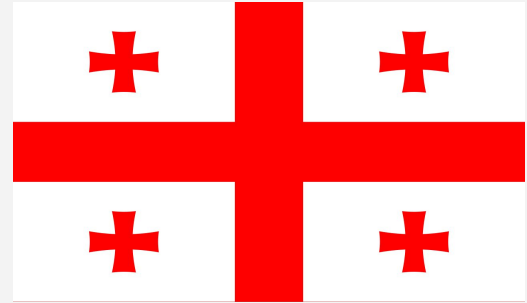

Rip to Zaire - Absolute Banger of a Flag



It got replaced with this, which is OK I guess

Q: Do you know what it is?

A: Democratic Republic of the Congo!

Let's look at Ugly Flags Together

- Now, let's look at some ugly flags!
- We've focused on sovereign nation flags for a reason
- City, provincial, and military flags often have lower standards
- Do your best to guess along!
Enjoy!

Q: You'll never guess where this is from



A: Pocatello, Idaho!

Fun fact this flag was so notoriously bad that they got bullied into replacing it

This one is for the Albertans!
Just because you can design it in Excel doesn't mean you should

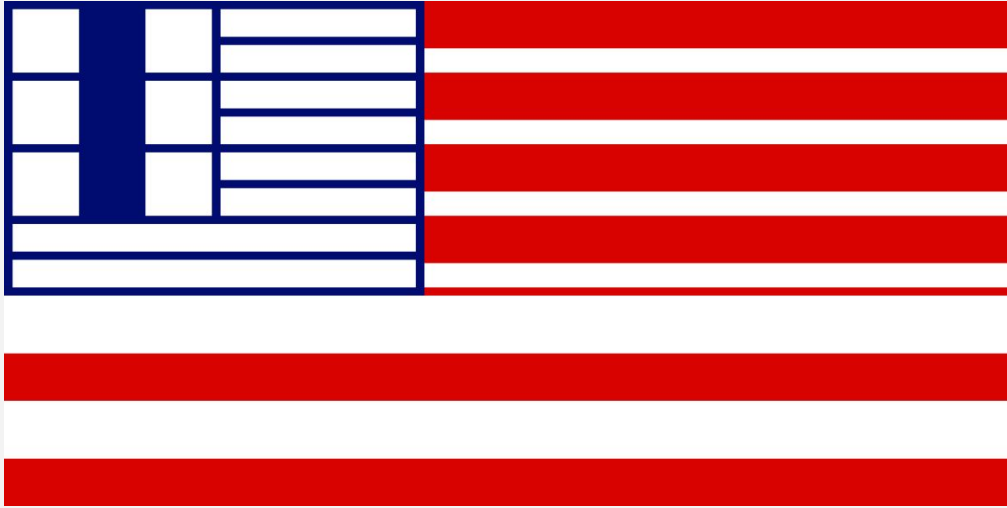

And yes, these flags are actually flown. This one was adopted in 1967.

Q: Which flag is it?

A: Flag of Lethbridge, Alberta

But it can get so much worse



So so so much worse

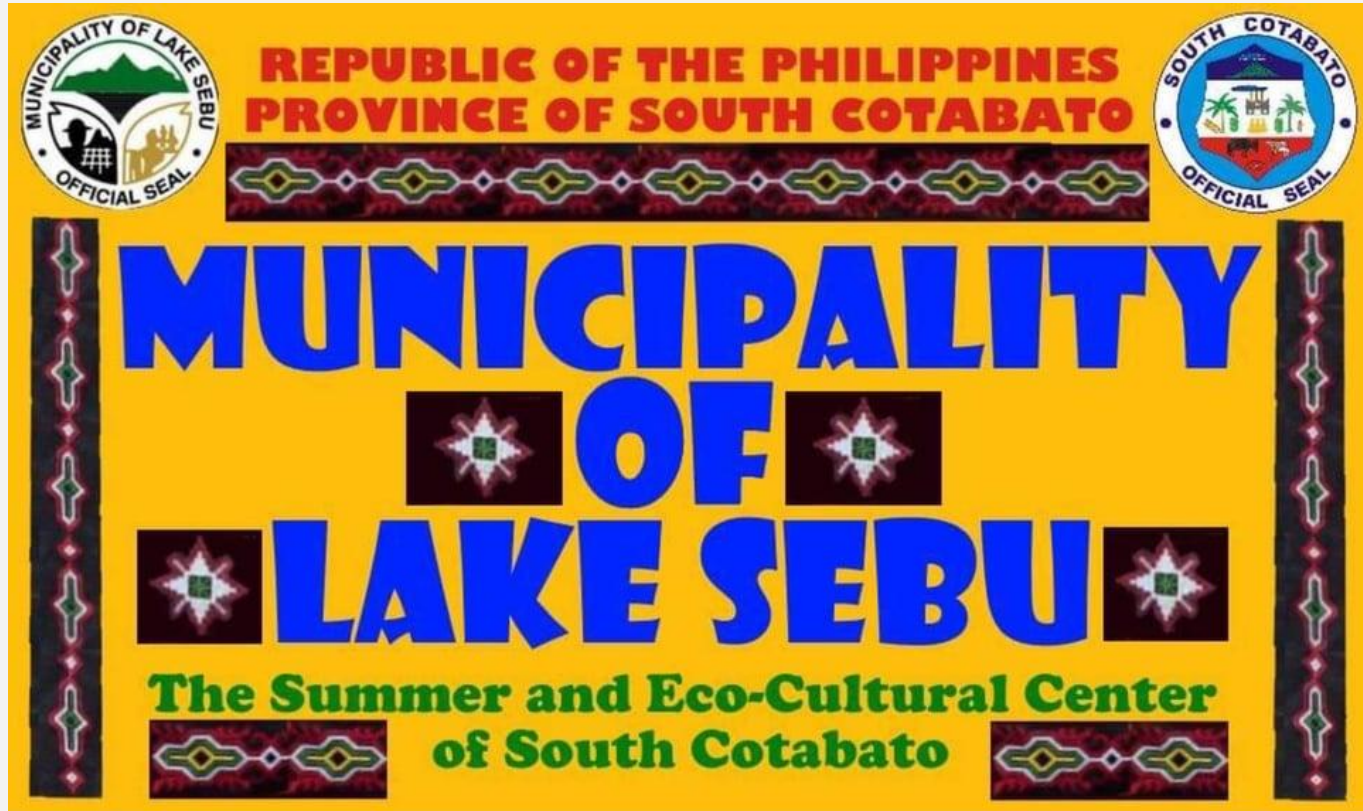

Or if you're this next country all of your county flags can be terrible

You are not ready for how truly ugly these are.

Q: Which country appears as a canton for each of these county flags in the next slide?

First person to say the answer correctly gets to pick three people to finish their drinks!

(If they're wrong they have to finish their drink)



Yes. These are real.

A: Liberia!
Drink up!

Let's look at good flags!
Here are some of my personal faves! :)

A: Top Left to bottom Right
Estonia, Antigua & Barbuda, Barbados,
Angola, Slovakia, St.Lucia

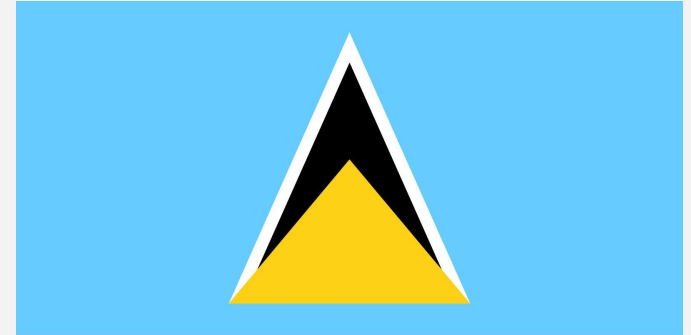
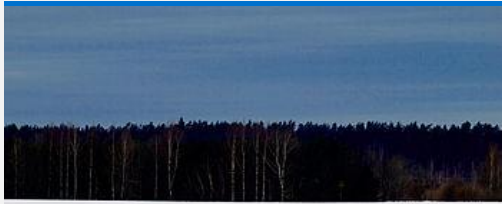

Sources

— — —

- “It's a Big Big World Atlas” - André Labrie
- “The world encyclopedia of flags” - Alfred Znamierowski
- [“Good Flag, Bad Flag: How to Design a Great Flag” by Ted Kaye](#)
- <https://en.wikipedia.org/wiki/Vexilloid>
- <https://nava.org/good-flag-bad-flag>
- [https://en.wikipedia.org/wiki/Glossary of vexillology](https://en.wikipedia.org/wiki/Glossary_of_vexillology)
- [https://en.wikipedia.org/wiki/List of flags by design](https://en.wikipedia.org/wiki/List_of_flags_by_design)
- [https://en.wikipedia.org/wiki/List of aspect ratios of national flags](https://en.wikipedia.org/wiki/List_of_aspect_ratios_of_national_flags)
- <https://www.allstarflags.com/facts/color-meanings-in-flags/>
- [Youtube - The Wacky World of Flags by Alternate History Hub](#)
- [Youtube - City Flags Are Abominations by Alternate History Hub](#)

Questions?

— — —

Some things I wanted to Cover but didn't want to add more slides to my 47 slide info dump:

- Pan Arab Colors (Green, Red, White, Black)
- Checkered Flags
- Pirate Flags

Thanks For Listening! :)